

10GBASE-ZR XFP 1550nm 80km Transceiver

P/N:QT-XFP-ZR



FEATURES

- XFP MSA Compliant
- data rate from 9.95 Gbps to 11.1Gbps
- No Reference Clock required
- Cold Start up Wavelength Compliance
- EML transmitter and APD receiver
- link length up to 80km
- Low Power Dissipation 3.5W Maximum
- -5°C to 70°C Operating Case Temperature
- Diagnostic Performance Monitoring of module temperature, supply Voltages,
- laser bias current, transmit optical power, receive optical power
- RoHS compliant and lead free

APPLICATIONS

- SONET OC-192&SDH STM 64
- 10G Ethernet
- 80 km 10G Fiber Channel

1. Absolute Maximum Ratings

Parameter	Symbol	Min	Max	Unit
Supply Voltage 1	Vcc3	-0.5	4.0	V
Supply Voltage 2	Vcc5	-0.5	6.0	V
Supply Voltage 3	Vcc2		2	
Storage Temperature	Tst	-40	85	°C
Case Operating Temperature	Top	-5	70	°C
Optical Input Received Power	APD-IN	-	-8	dBm

2. Operating Conditions

Parameter	Symbol	Min	Typical	Max	Unit
Supply Voltage 1	Vcc3	3.13	3.3	3.47	V
Supply current 1	Icc3			750	mA
Supply Voltage 2	Vcc5	4.75	5	5.25	V
Supply current 2	Icc5			500	mA
Supply Voltage 3	Vcc2	1.71	1.8	1.89	V
Supply current 3	Icc2			750	mA
Operating Case temperature	Tca	-5	-	70	°C
Module Power Dissipation	Pm	-		3.5	W

3. Transmitter Specifications – Optical

Parameter	Symbol	Min	Typical	Max	Unit
Data Rate Multirate	Mra	9.95	-	11.1	Gbps
Center Wavelength	c		1550		nm
Optical Transmit Power	Po	0	-	+5	dBm
Optical Transmit Power (disabled)	PTX_DISABLE	-	-	-30	dBm
Extinction Ratio	ER	8.2		-	dB
Channel Spacing	Δf	-	100	-	GHz
Jitter Generation	TJP-P	-	-	0.1	UI
Spectral Width (-20dB)	DI20	-	0.1	0.3	nm
Side Mode Suppression Ratio	SMSR	30	-	-	dB
Dispersion penalty(800ps/nm)	DP			2	dB
Eye Mask	Compliant with ITU-T G.691 STM-64 eye mask				

Transmitter Specifications – Electrical

Parameter	Symbol	Min	Typical	Max	Unit
Input differential impedance	Rim	-	100	-	Ω
Differential data Input	VtxDIFF	120	-	850	mV
Transmit Disable Voltage	VD	2.0	-	Vcc3+0.3	V

Transmit Enable Voltage	Ven	0	-	+0.8	V
Transmit Disable Assert Time	Vn	-	-	10	us

4. Receiver Specifications – Optical

Parameter	Symbol	Min	Typical	Max	Unit
Data Rate Multirate	Mra	9.95	-	11.1	Gbps
Receiver Sensitivity 9.95Gb/s	Rsens9	-	-	-24	dBm
Receiver Sensitivity 10.7Gb/s	Rsens10	-	-	-23	dBm
Maximum Input Power	RX-overload	-	-	-7	dBm
Input Operating Wavelength	λ	1528	-	1564	nm
Reflectance	Rrx	-	-	-27	dB
Loss of Signal Asserted		-34	-	-	dBm
LOS De-Asserted		-	-	-24	dBm
LOS Hysteresis		0.5	-	-	dB

Receiver Specifications – Electrical

Parameter	Symbol	Min	Typical	Max	Unit
Differential Output Swing	Vout P-P	350	-	850	mV
Rise/Fall Time	Tr / Tf	24	-	-	ps
Loss of Signal –Asserted	VOH	2	-	Vcc3+0.3-	V
Loss of Signal –Negated	VOL	0	-	+0.4	V

5. Low Speed Electrical Signal Timings

Parameter	Symbol	Min	Typical	Max	Unit
TX Disable, Power_Down/RST	VIH	2.0		Vcc3+0.3	V
	VIL	-0.3		0.8	V
Interrupt, Mod_NR, Rx_Los	VOH	Vdd3-0.5		Vdd3+0.3	V
	VOL	0		0.4	V
SCL,SDA(IN)	VIH	Vdd3*0.7		Vdd3+0.5	V
	VIL	-0.3		Vdd3*0.3	V
SCL,SDA(OUT)	VOH	Vdd3-0.5		Vdd3+0.3	V
	VOL	0		0.4	V
I2C clock rate	t_reset		-	400	KHz
Leakage current	IL	-	-	100	uA

6. Pin Descriptions

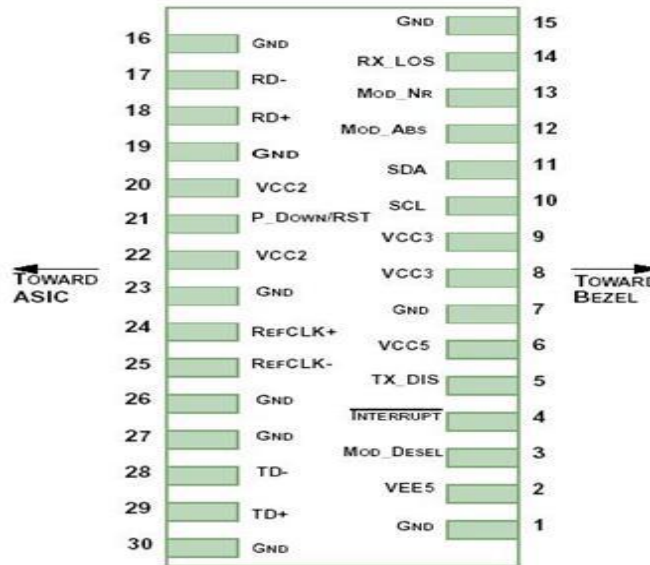

Pin	Logic	Symbol	Name/Description	Ref.
1		GND	Module Ground	1
2		VEE5	Optional -5.2 Power Supply – Not required	
3	LVTTL-I	Mod-Desel	Module De-select; When held low allows the module to respond to 2-wire serial interface commands	
4	LVTTL-O	Interrupt	Interrupt (bar); Indicates presence of an important condition which can be read over the serial 2-wire interface	2
5	LVTTL-I	TX_DIS	Transmitter Disable; Transmitter laser source turned off	
6		VCC5	+5 Power Supply	
7		GND	Module Ground	1
8		VCC3	+3.3V Power Supply	
9		VCC3	+3.3V Power Supply	
10	LVTTL-I	SCL	Serial 2-wire interface clock	2
11	LVTTL-I/O	SDA	Serial 2-wire interface data line	2
12	LVTTL-O	Mod_Abs	Module Absent; Indicates module is not present. Grounded in the module.	2
13	LVTTL-O	Mod_NR	Module Not Ready;	2
14	LVTTL-O	RX_LOS	Receiver Loss of Signal indicator	2
15		GND	Module Ground	1
16		GND	Module Ground	1
17	CML-O	RD-	Receiver inverted data output	
18	CML-O	RD+	Receiver non-inverted data output	
19		GND	Module Ground	1
20		VCC2	+1.8V Power Supply	
21	LVTTL-I	P_Down/RST	Power Down; When high, places the module in the low power stand-by mode and on the falling edge of P_Down initiates a module reset	
			Reset; The falling edge initiates a complete reset of the module	

			including the 2-wire serial interface, equivalent to a power cycle.	
22		VCC2	+1.8V Power Supply	
23		GND	Module Ground	1
24	PECL-I	RefCLK+	Reference Clock non-inverted input, AC coupled on the host board – Not required	3
25	PECL-I	RefCLK-	Reference Clock inverted input, AC coupled on the host board – Not required	3
26		GND	Module Ground	1
27		GND	Module Ground	1
28	CML-I	TD-	Transmitter inverted data input	
29	CML-I	TD+	Transmitter non-inverted data input	
30		GND	Module Ground	1

Notes:

1. Module circuit ground is isolated from module chassis ground within the module.
2. Open collector; should be pulled up with 4.7k – 10k ohms on host board to a voltage between 3.15V and 3.6V.
3. A Reference Clock input is not required.

7. Mechanical Specifications

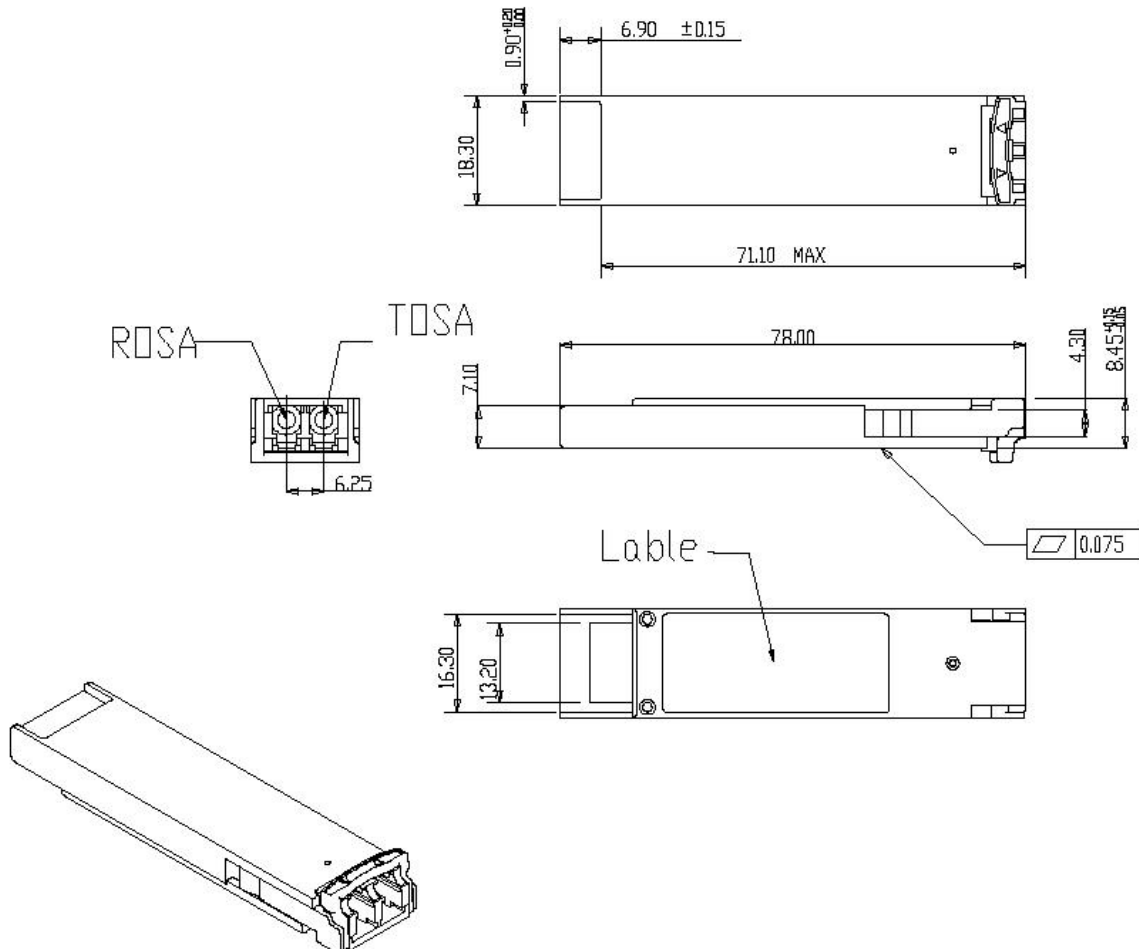

8. Ordering information

Part Number	Product Description
QT-XFP-ZR	XFP,10Gbps ,1550nm,SMF,80KM, DDM,LC connector, -5°C ~ +70°C